

Manual SK550 1.1

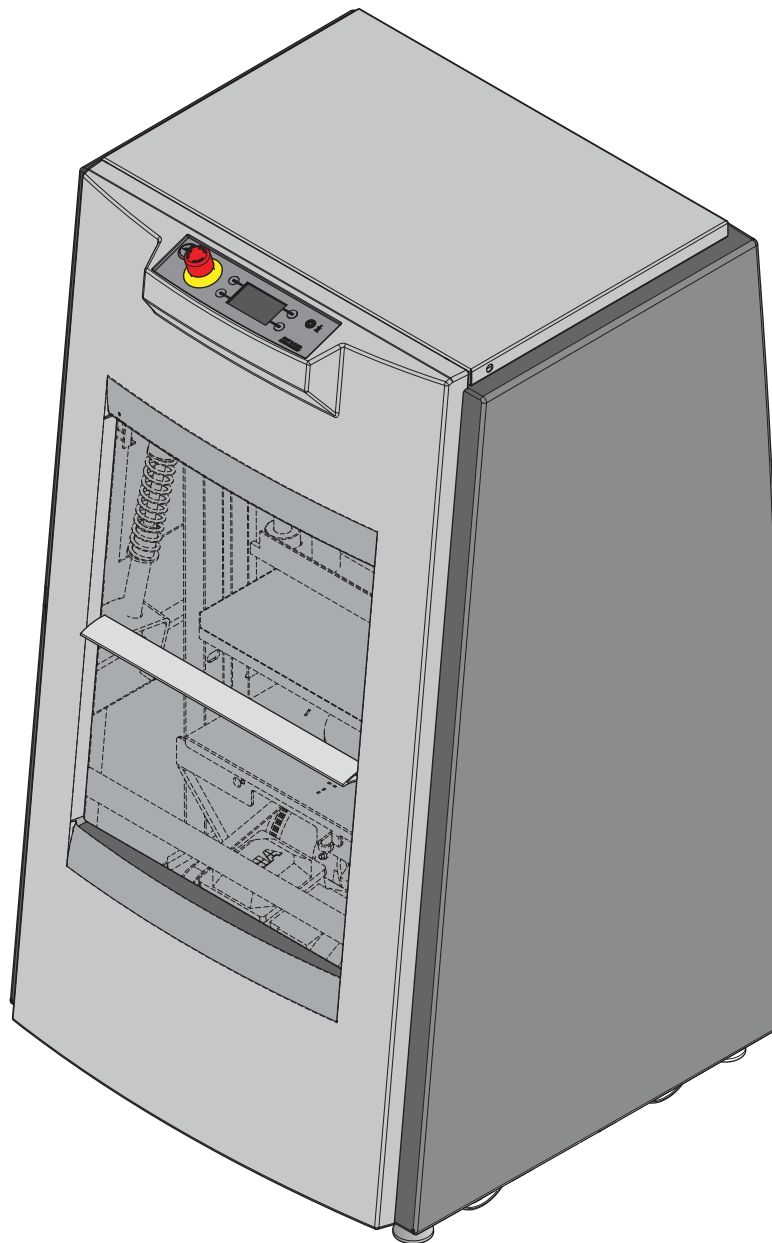

© **Fast & Fluid Management B.V.**

This manual or parts thereof may not be reproduced, stored in a retrieval system, or transmitted, in any form or by any means, electronic, mechanical, photocopying, recording, nor otherwise, without the prior written permission of Fast & Fluid Management B.V.

This manual could contain technical inaccuracies or typographical errors.

Fast & Fluid Management B.V. reserves the right to revise this manual from time to time in the contents thereof without the obligation of Fast & Fluid Management B.V. to notify any person of such revision or change.

Details and values given in this manual are average values and have been compiled with care. They are not binding, however, and Fast & Fluid Management B.V. disclaims any liability for damage or detriments suffered as a result of reliance on the information given herein or the use of products, processes or equipment to which this manual refers. No warranty is made that the use of the information or of the products, processes or equipment to which this manual refers will not infringe any third party's patents or rights. The information given does not release the user from making their own experiments and tests.

Table of Contents

1	About this manual	5
1.1	How to work with the manual.....	5
1.2	Record of changes	5
2	Safety	7
2.1	Intended use.....	7
2.2	Liability.....	7
2.2.1	General liability	7
2.2.2	Machine-specific liability	7
2.3	User qualification for installation.....	7
2.4	CE certification	7
2.5	Safety symbols on the machine.....	8
2.6	Safety symbols in the manual.....	8
2.7	Disposal of the machine	8
3	Operator manual	9
3.1	Description.....	9
3.1.1	Overview of the machine	9
3.1.2	Overview of the control panel.....	10
3.1.3	Type plate: serial number	10
3.1.4	Type plate: details	10
3.2	Operation.....	11
3.2.1	Turning on the machine.....	11
3.2.2	Turning on the machine when the machine is in hibernation	11
3.2.3	General shaking procedure	11
3.2.4	Placing the can.....	11
3.2.5	Start the machine	13
3.2.6	Adjust the shake time during operation (optional)	13
3.2.7	Remove the can	14
3.2.8	Stop the operation manually.....	14
3.2.9	Using the emergency stop switch.....	14
3.2.10	Restart the machine	14
3.3	Maintenance	15
3.3.1	General safety instructions for maintenance	15
3.3.2	General cleaning: after every operation	15
3.3.3	Periodic maintenance: weekly	15
3.3.4	Periodic maintenance: monthly	15

4	Installation	17
4.1	Unpack the machine.....	17
4.1.1	Remove the cardboard.....	17
4.1.2	Remove the plastic foil	17
4.1.3	Unlock the machine.....	18
4.1.4	Remove the wooden blocks	18
4.1.5	Remove the transport brackets	19
4.1.6	Remove the wooden beams.....	19
4.1.7	Dispose of the packaging material	19
4.2	Put the machine in position	20
4.2.1	Move the machine from the pallet	20
4.2.2	Move the machine to the final location	20
4.2.3	Level the machine	21
4.3	Finish the installation	21
4.4	Select the user ID code	21
5	Troubleshooting.....	23
5.1	General troubleshooting procedure	23
5.2	Contact service.....	23
5.3	Error messages and other faults	23
6	Technical data	25
6.1	General specifications	25
6.2	Dimensions and mass	25
6.3	Ambient conditions	25
6.4	Noise level.....	26
6.5	Safety classifications	26
6.6	Electrical specifications	26
6.7	Electrical diagram.....	27

1 About this manual

The manual shows the information necessary to:

- install
- operate
- perform basic maintenance
- correct small problems.

The SK550 1.1 and all its versions are referred to in the manual as the 'machine'.

This manual contains the original instructions. The original language of the manual is English. All other language versions are translations of the original instructions.

1.1 How to work with the manual

For the safe use of the machine, it is important:

- 1 To familiarize yourself with the structure and content.
- 2 To read the safety chapter in detail and make sure you understand all the instructions. See § 2.
- 3 To carry out the actions completely and in the given sequence.

1.2 Record of changes

Edition	Editor	Check	Date	Description
1.0	ET	TB	03/2015	First edition

2 Safety



WARNING

Read the manual before you install or use the machine. Failure to do so can result in personal injury, death or property damage.

2.1 Intended use

The machine is designed to shake colorants in a can. Any other use of the machine is strictly forbidden.

2.2 Liability

2.2.1 General liability

Our machines and accessories are fully compliant with the CE regulations. Any modification can result in not fulfilling the CE safety requirements and is therefore not allowed. Fast & Fluid Management B.V. will not accept any responsibility in case of modifications to machines and/or accessories.

Fast & Fluid Management B.V. is not liable if you do not follow the rules below:

- The machine is for indoors use only.
- This machine may only be used for commercial settings. The machine is not a household appliance.
- Observe all local safety regulations.
- Mind the minimal requirement of the building structure of the load capacity of the floor.
- Place machine in a well-lit and well ventilated room.
- Install and connect the machine according to the instructions in this manual.
- Connect the machine to a grounded wall socket.
- Do not use extension cords or inadequately rated power cables.
- Make sure that the power cable is freely accessible.
- Do not place objects on top of the machine.
- Do not use a damaged machine. When you have doubts, contact your supplier. See § 5.2.
- Keep the machine in good condition. Make sure that defective parts are immediately replaced.
- Replace parts only with original Fast & Fluid Management B.V. spare parts.

All maintenance beyond the scope of this manual must be carried out by a qualified service technician that Fast & Fluid Management B.V. has trained and certified.

2.2.2 Machine-specific liability

The machine cannot be used in an environment where explosive vapours may occur (ATEX zone). Colorants that contain flammable solvents can be shaken as long as they are packed in a suitable UN approved container.

2.3 User qualification for installation

Only install the machine if you have written permission from the supplier of the machine.

2.4 CE certification

The machine is CE certified. This means that the machine complies with the essential requirements concerning safety. The directives that have been taken into consideration in the design are available on www.fast-fluid.com.

2.5 Safety symbols on the machine



CAUTION
Disconnect power supply
before servicing



Read the manual



Maximum load weight.
See § 6.1



Central earthing point

2.6 Safety symbols in the manual



WARNING
Can cause personal injury.



Note
Shows further information.



CAUTION
Can cause damage to the machine.

2.7 Disposal of the machine

1. Sort the machine, the accessories and the packaging for environmentally friendly recycling.
2. Do not dispose of the machine into domestic waste. Dispose of the machine according to local regulations.

3 Operator manual

3.1 Description

3.1.1 Overview of the machine

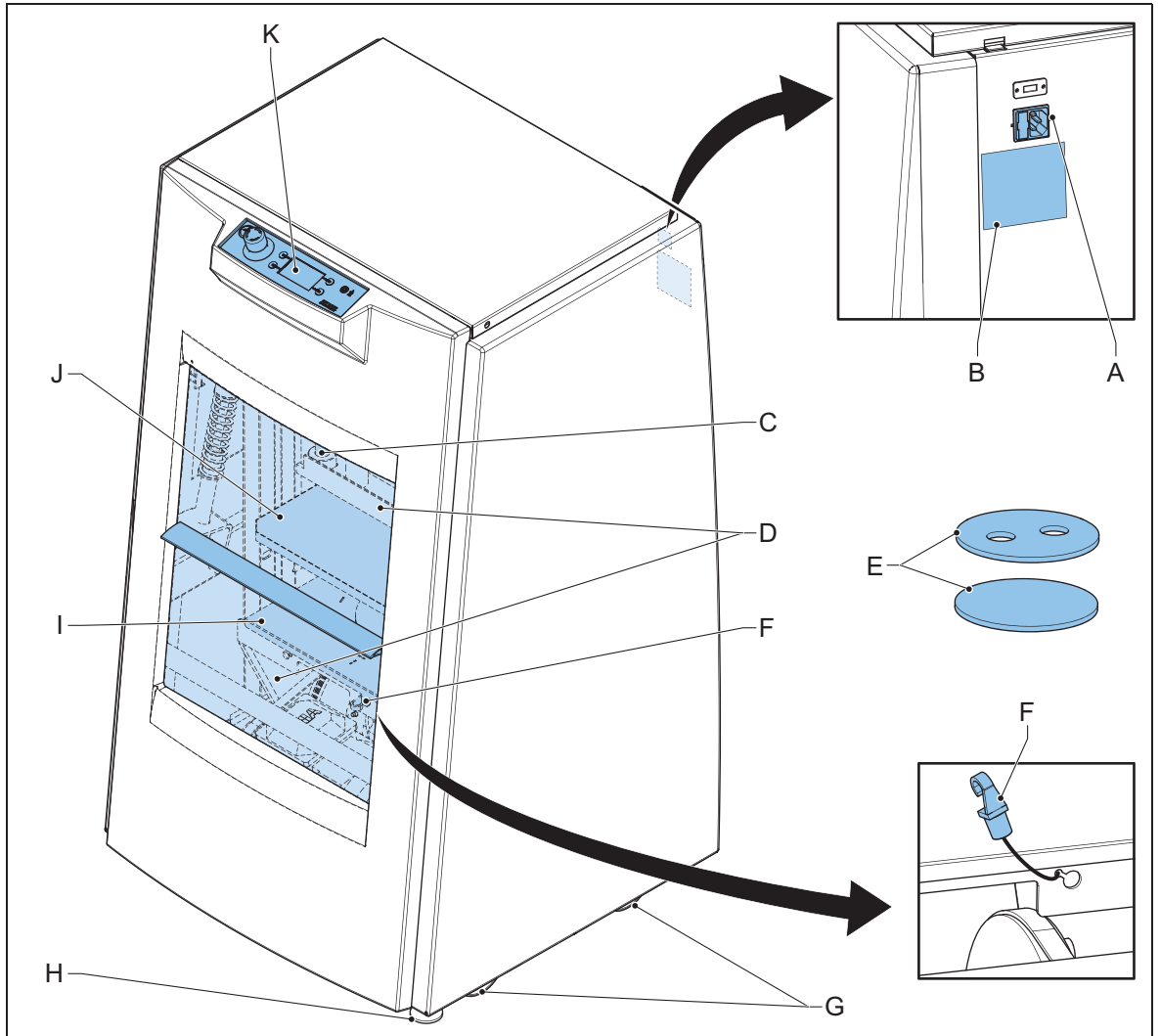

- A:** Net entry
- B:** Type plate
- C:** Spindle
- D:** Door
- E:** Lid padding
- F:** Can handle retainer

- G:** Adjustable foot
- H:** Wheels
- I:** Can table
- J:** Can plate
- K:** Control panel

3.1.2 Overview of the control panel

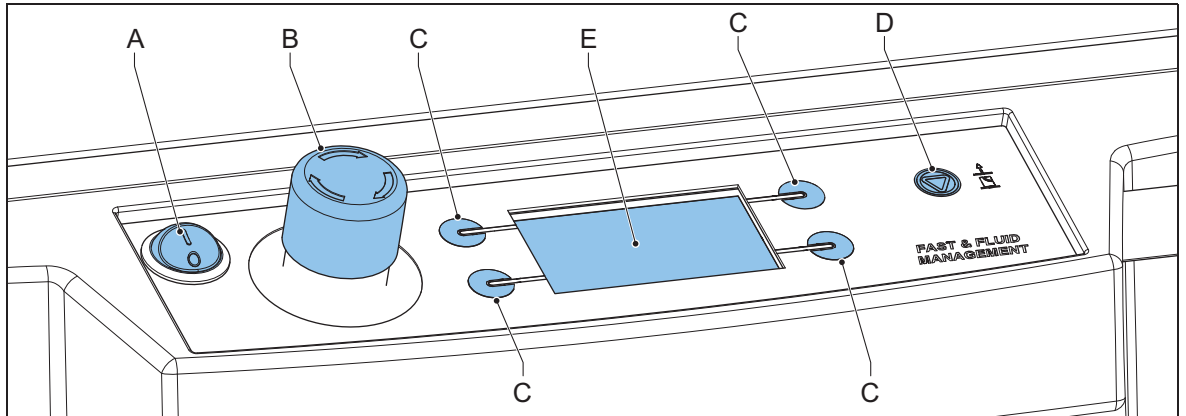

- A: Main switch
- B: Emergency stop switch
- C: Program keys
- D: Stop/Up key
- E: Display



Note
The display shows the program menu.

3.1.3 Type plate: serial number

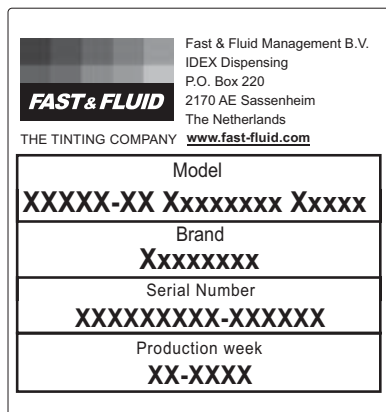

3.1.4 Type plate: details

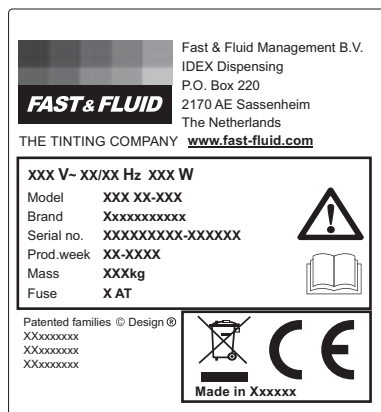

3.2 Operation



WARNING

Only push the emergency stop switch in case of a safety emergency.

3.2.1 Turning on the machine

1. Connect the power cable to the grounded wall socket.
2. Make sure that the emergency stop switch is released.
3. Set the main switch to 'ON'. *When the machine is on, the display shows the default shake times.*



Note

For first time use, select the user ID code. See § 4.4.

3.2.2 Turning on the machine when the machine is in hibernation

When the machine is in hibernation, the illumination of the display is off and the display shows the Fast & Fluid logo.

1. Push any key. *When the machine is on, the display shows the default shake times.*

3.2.3 General shaking procedure

1. Place the can. See § 3.2.4.
2. Start the machine, See § 3.2.5.
3. Wait until the display shows "Ready!". *The door is unlocked.*
4. Remove the can. See § 3.2.7.

3.2.4 Placing the can

Open the doors

1. Open the doors (A). *Use the handle (B).*

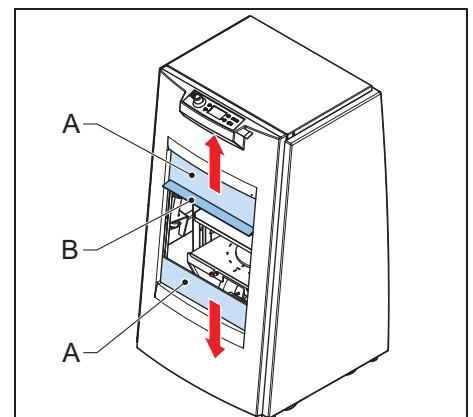

Place the can

1. Put one or more cans (A) in the centre of the can table, or in a pattern that has its gravitational centre in the middle of the can table.



WARNING

It is possible that the can is heavy. Use the correct lifting tool when appropriate. Obey the local regulations.



CAUTION

Make sure that all cans have the same height. Do not stack cans upon each other.



Note

If the can plate and the can table are too close to each other, use the Stop/Up key to move the can plate upwards.

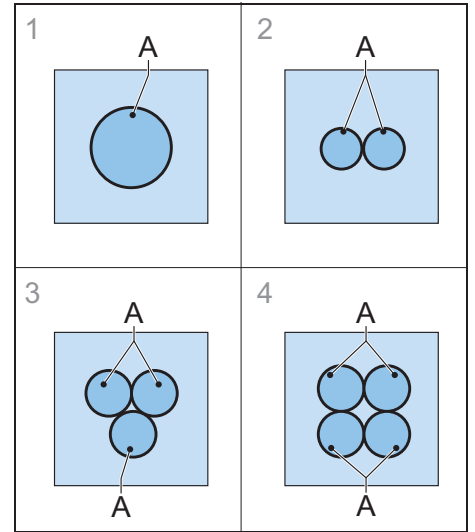

Retain the can handle

1. If you place one can, make sure that the can handle (A) cannot move. Use the can handle retainer (B).
2. If you place more than one can at the same time, make sure that the can handles cannot move. Use a can handle retainer, for example self-adhesive tape.

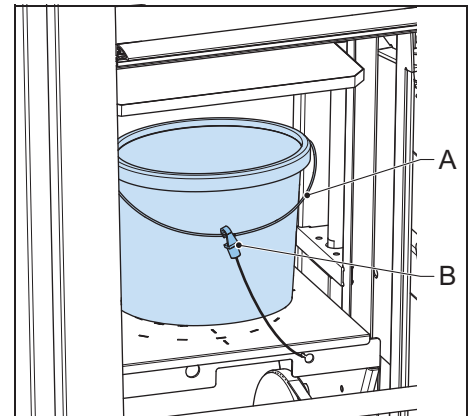

Retain the can (optional)



Note

Sometimes the space between the lid of the can and the can plate causes the can to move during operation. Use the lid padding to prevent the displacement of the can.

1. Put the lid padding on the can.

Close the doors

1. Close the doors (A). Use the handle (B).

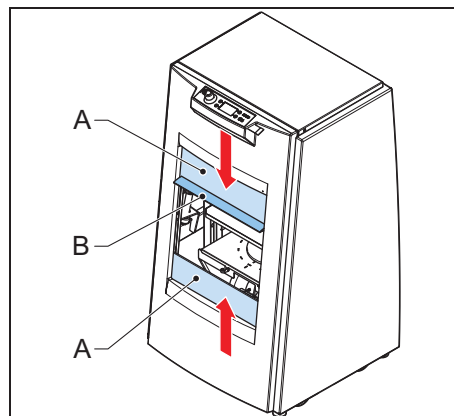
**3.2.5 Start the machine**

1. Select the shake time by pushing one of the program keys.
The doors are locked and the machine starts.

**Note**

The default shake times are 30, 60, 120 and 180 seconds.

3.2.6 Adjust the shake time during operation (optional)**Note**

During operation:

- The display shows the remaining shake time.
- You can adjust the shake time.

1. Use the program keys to increase (+) or decrease (-) the shake time.

3.2.7 Remove the can

1. Open the doors (A). Use the handle (B).
2. Remove the can handle retainer from the can handle.
3. Remove the can.



Note

If the can plate and the can table are too close to each other, use the Stop/Up key to move up the can plate.

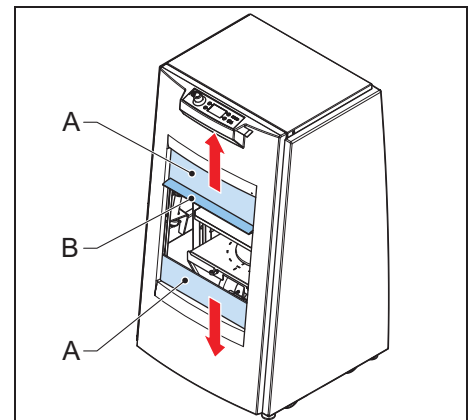

3.2.8 Stop the operation manually

1. Push the Stop/Up key.
2. Wait until the display shows "Ready!". *The doors are unlocked.*
3. If necessary, remove the can. See § 3.2.7.

3.2.9 Using the emergency stop switch

1. Push the emergency stop switch (A). The machine stops immediately.



CAUTION

Only push the emergency stop switch in case of a safety emergency. Do not use the emergency stop switch as an on/off function!

2. Solve the problem as quickly as possible.
3. Reset the emergency stop switch by turning the emergency stop switch. The machine restarts automatically.



Note

After the reset, the machine is on and initiated when the display shows the shake times.

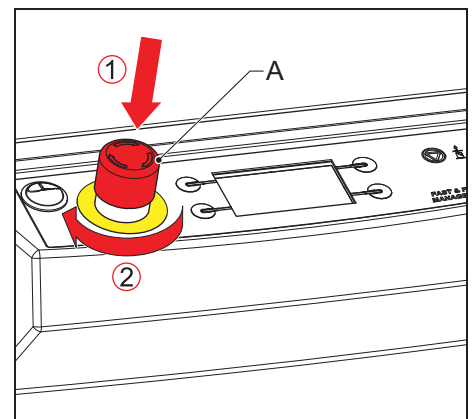

3.2.10 Restart the machine

1. Set the main switch to the off position.
2. Wait 30 seconds.
3. Turn on the machine. See § 3.2.1.

3.3 Maintenance

3.3.1 General safety instructions for maintenance

**WARNING**

Check the MSDS of the colorants about personal protection measures required for handling the colorant.

**CAUTION**

Do not use cleaning agents based on organic solvents to clean the machine.

3.3.2 General cleaning: after every operation

1. Clean the machine with a cloth and remove all spilled paint or other liquid.

3.3.3 Periodic maintenance: weekly

1. Remove all spilled paint from the machine.
2. Grease the spindles.

3.3.4 Periodic maintenance: monthly

1. Remove all spilled paint and dirty grease from the machine.
2. Add new grease.
3. Grease the sliding parts.

4 Installation

4.1 Unpack the machine

4.1.1 Remove the cardboard

1. Remove the cardboard (A).

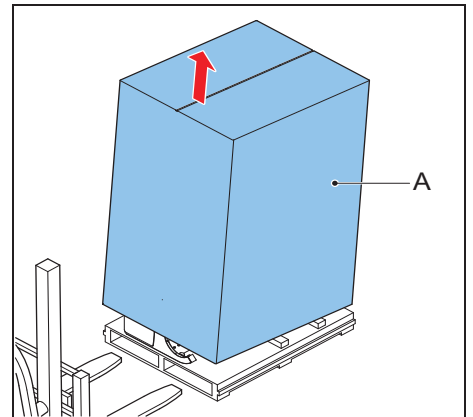

4.1.2 Remove the plastic foil

1. Remove the plastic foil (A).

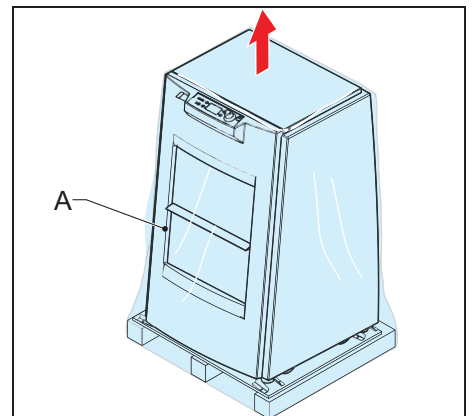

4.1.3 Unlock the machine

1. Remove the bolts (A) at both sides of the machine. *The wooden blocks (B) are now free to move.*

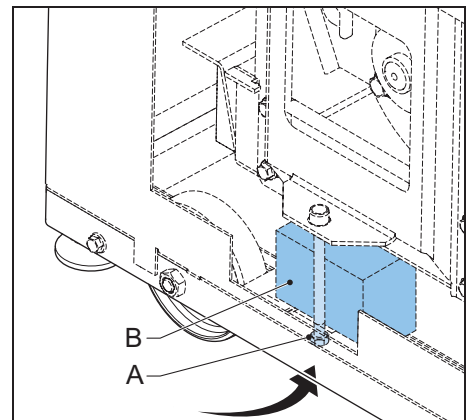

4.1.4 Remove the wooden blocks



CAUTION

If you do not remove all loose parts, this can cause severe damage to the machine when it is in operation.

1. Remove the wooden blocks from the machine. *Use the cord (A).*
2. Make sure that all loose parts are removed from the machine:



Note

Store the removed parts for later use. They are needed for future transportation.

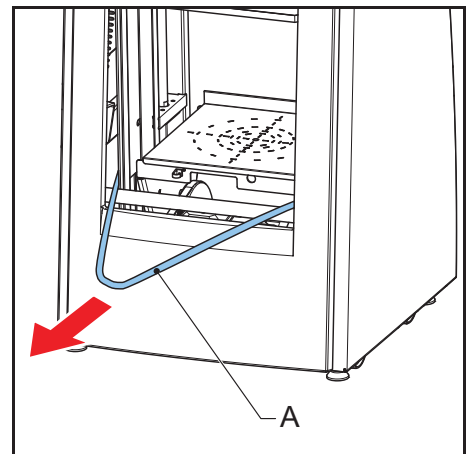

4.1.5 Remove the transport brackets

1. Remove the screws (A).
2. Remove the transport brackets (B).

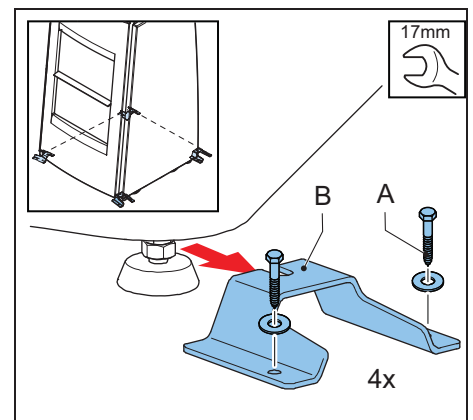
**4.1.6 Remove the wooden beams**

1. Remove the wooden beams (A).

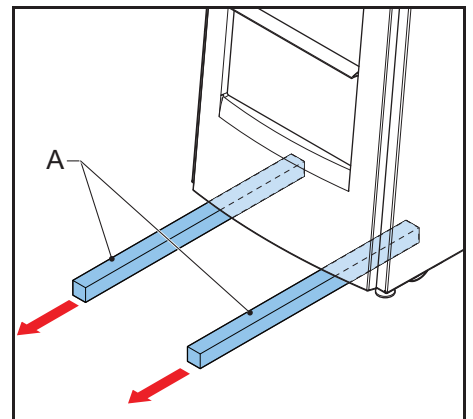
**4.1.7 Dispose of the packaging material**

1. Dispose of the packaging material in an environmentally friendly way, according to local regulations.

4.2 Put the machine in position

4.2.1 Move the machine from the pallet

1. Optionally, place a ramp (A).
2. Push the machine from the pallet on to the ground.

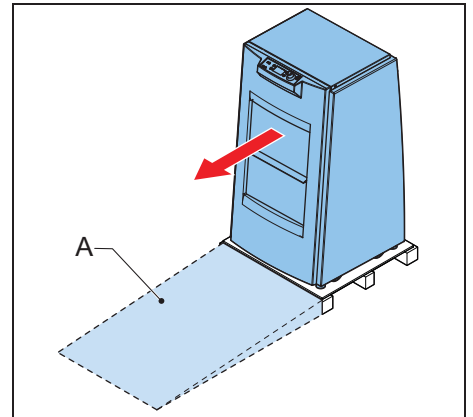

4.2.2 Move the machine to the final location

**WARNING**

Mind the minimum requirement of the load capacity of the floor. See § 6.2.

**Note**

Make sure the final location is well-lit and well-ventilated.

1. Push the machine to the final location.
2. Connect the power cable to the net entry.
3. Connect the power cable to the wall socket.

**Note**

The power cable is also used as a device to disconnect the power.

4.2.3 Level the machine

1. Move down the adjustable feet (B) until the wheels (A) are off the ground.
2. Adjust the height of the feet and make sure that the machine is leveled.
3. Tighten the nuts (C) to lock the feet.

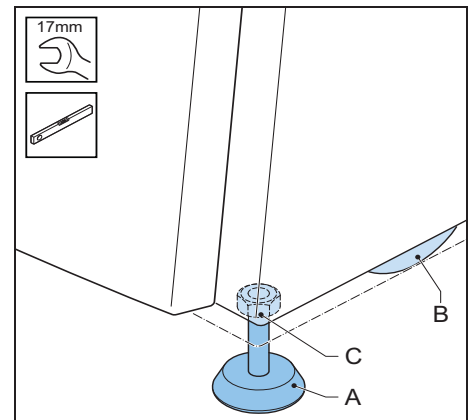

4.3 Finish the installation

1. Turn on the machine. See § 3.2.1.
2. For first time use, select the user ID code. See § 4.4.

4.4 Select the user ID code



Note
The default user ID code is “0000”.



Note
You can choose a user ID code only one time. If you have chosen the wrong user ID code, the machine uses the default user ID code. See § 5.3.

1. Select the user ID code. *Use the program keys.* Refer to the table.
2. Choose the user ID code. *Use the Stop/Up key (E).*

Key	Function
A	To go to the previous value of the digit
B	To go to the next value of the digit
C	To increase the value of the digit
D	To decrease the value of the digit

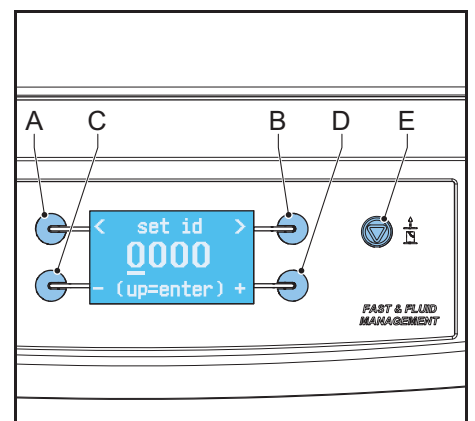

5 Troubleshooting

5.1 General troubleshooting procedure

1. Try to solve the problem with the information in this manual. See § 5.3.
2. If it is not possible to solve the problem with the information in this manual, contact service. See § 5.2.

5.2 Contact service

1. Find the type plate on the rear of the machine. See § 3.1.4.
2. Take a note of the model number and the serial number of the machine.
3. Contact your supplier or manufacturer.
See www.fast-fluid.com.

5.3 Error messages and other faults



Note

See the column *Possible solution* to solve the problem. When the problem persists, contact service. See § 5.2.

Problem	Possible cause	Possible solution
The display shows 'E01'	The door is open.	Close the door. See § 3.2.4.
The display shows 'E08'	Emergency stop is pressed during running state.	Release the emergency stop. See § 3.2.9.
The display shows 'E11'	The can is missing.	Place the can. See § 3.2.4.
The display shows 'E50' to 'E99'	Inverter is in error mode.	Reset the machine. See § 3.2.10.
The display shows user ID code '0000', but you have chosen another user ID code	The wrong user ID code is chosen.	Contact service. See § 5.2.

6 Technical data

6.1 General specifications

Parameter	Specification
Materials used are suitable for	Water, universal and solvent colorants
Maximum load weight [kg]	40
Can table dimensions [cm]	36 x 35
Maximum can height [cm]	45
Minimum can height [cm]	7
Maximum shake speed [rpm]	720
Maximum shake time [s]	999

6.2 Dimensions and mass

Parameter	Specification
Dimensions, height x width x depth [cm]	116 x 72 x 61
Packed dimensions, height x width x depth [cm]	160 x 78 x 78
Mass incl. packaging [kg]	210
Mass filled machine [kg]	230
Minimum requirement of the load capacity of the floor according to EN 61010-1:2010 [kg]	920

6.3 Ambient conditions

Parameter	Specification
Temperature [°C], operational	+15 to +40
Temperature [°C], out of operation	-25 to +55
Altitude above sea level [m], operational	-10 to 2000
Altitude above sea level [m], out of operation	-10 to 12000
Maximum relative humidity [RH], without condensation [%]	90

6.4 Noise level

Parameter	Specification
Maximum noise level [dB(A)]	<65

6.5 Safety classifications

Parameter	Specification
IP (Ingress Protection) classification	32
EMC (ElectroMagnetic Compliancy) classification	Class B
Overvoltage category	Class II

6.6 Electrical specifications

Parameter	Specification
Power consumption, maximum [W]	1000
Maximum leakage current [mA]	3.5
Country specific net cables	European
Voltage [V]	230
Frequency [Hz]	50/60
Fuse specifications [A]	10

6.7 Electrical diagram

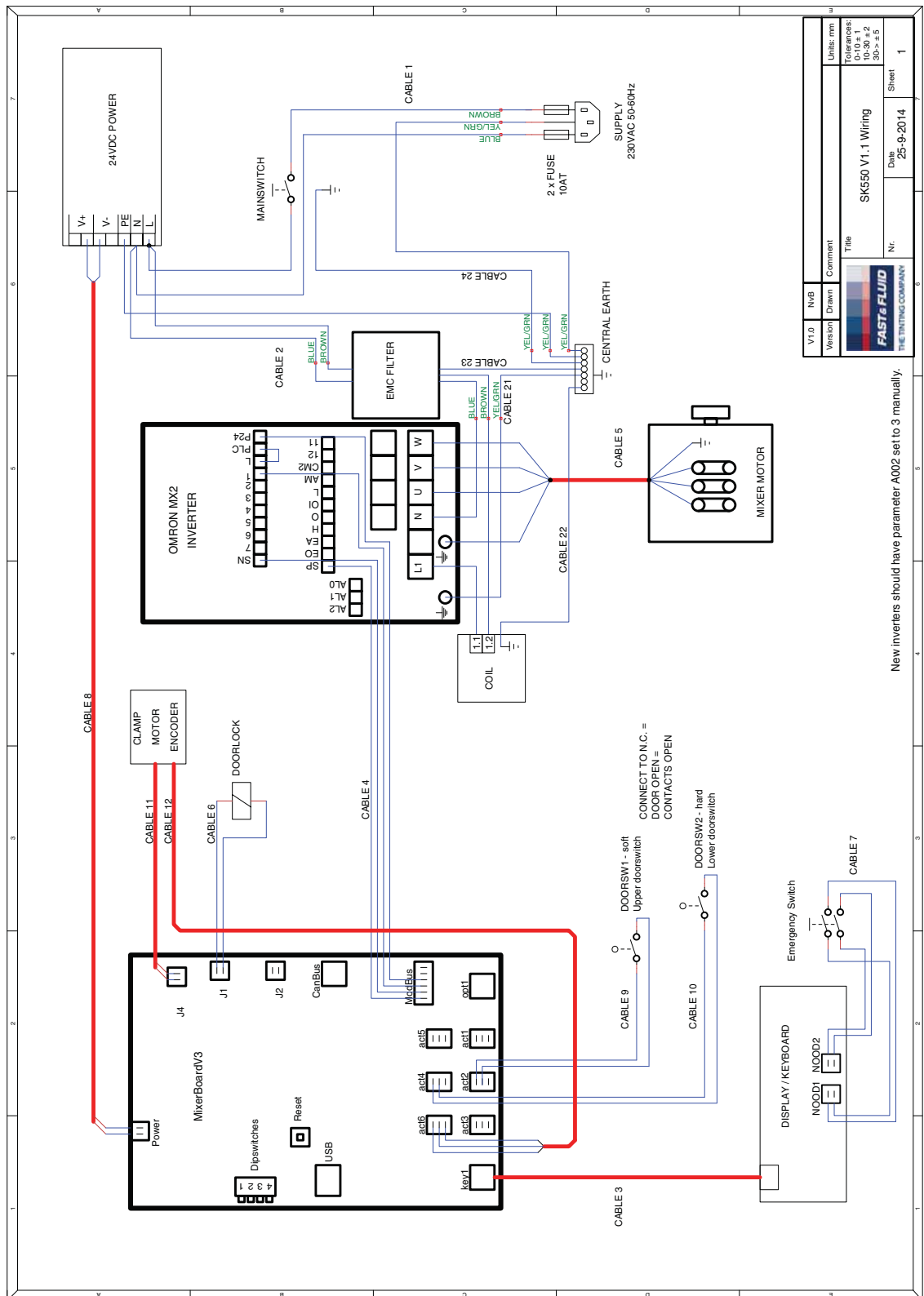

V1.0	Nr. 8	Comment	Units: mm
Title			Tolerances:
SK550 V1.1 Wiring			10-9 > ± 2
Nr.			30-9 > ± 5
Date			Sheet
25-9-2014			1

New inverters should have parameter A002 set to 3 manually.

